



**QSCP-200/300**

**Four Channel RS-422/485 Asynchronous  
Communications Adapter**

**for Compact PCI (cPCI) bus**

**User's Manual**

QUATECH, INC.  
662 Wolf Ledges Parkway  
Akron, Ohio 44311

TEL: (330) 434-3154  
FAX: (330) 434-1409  
<http://www.quatech.com>

## WARRANTY INFORMATION

Quatech, Inc. warrants the **QSCP-200/300** to be free of defects for **five (5) years** from the date of purchase. Quatech, Inc. will repair or replace any board that fails to perform under normal operating conditions and in accordance with the procedures outlined in this document during the warranty period. Any damage that results from improper installation, operation, or general misuse voids all warranty rights.

Please complete the following information and retain for your records. Have this information available when requesting warranty service.

DATE OF PURCHASE:

MODEL NUMBER:                QSCP-200/300

PRODUCT DESCRIPTION: Four Channel RS-422/485 Asynchronous  
PCI Bus Communications Adapter

SERIAL NUMBER:

## Declaration of Conformity

**Manufacturer's Name:** Quatech Inc.

**Manufacturer's Address:** 662 Wolf Ledges Parkway  
Akron, Ohio 44311 (USA)

**Application of Council Directive:** 89/336/EEC

**Standards to which  
Conformity is Declared:** \* EN50081-1 (EN55022,  
EN60555-2, EN60555-3)  
\* EN50082-1 (IEC 801-2,  
IEC 801-3, & IEC 801-4)

**Type of Equipment:** Information Technology  
Equipment

**Equipment Class:** Commercial, Residential, & Light  
Industrial

**Product Name:** PCI Quad Serial Communications Card

**Model Number :** QSCP-200/300 (750,IND)

## Table of Contents

<b>1 General Information</b> .....	1
Optional Features .....	2
<b>2 Hardware Configuration</b> .....	3
RS-422 or RS-485 Signal Line Termination .....	3
Signal Connections .....	4
Full-duplex/Half-duplex Operation .....	4
Clock Rate and Optional Registers .....	6
Enable Scratchpad Registers (SPAD, J5) .....	6
Force High-Speed UART Clock (X2, X4, or X8, J3-J5) .....	7
<b>3 Hardware Installation</b> .....	8
<b>4 Address Map and Special Registers</b> .....	9
Base Address and Interrupt Level (IRQ) .....	9
Enabling the Special Registers .....	10
Interrupt Status Register .....	10
Options Register .....	11
Enhanced Serial Adapter Identification .....	11
Clock Rate Multiplier .....	11
<b>5 Windows Configurations</b> .....	13
Windows Millennium .....	13
Windows 2000 .....	14
Windows 98 .....	15
Windows 95 .....	17
<b>6 Other Operating Systems</b> .....	21
Windows NT .....	21
OS/2 .....	21
DOS and other operating systems .....	21
QTPCI.EXE .....	21
<b>7 External Connections</b> .....	24
RTS/CTS Handshake .....	25
RCLK .....	25
XCLK .....	27
AUXIN/AUXOUT Loopback .....	27
Half-Duplex/Full-Duplex Selection .....	28
Termination Resistors .....	31
RS-422/485 Peripheral Connection .....	32
<b>8 PCI Resource Map</b> .....	34
<b>9 Specifications</b> .....	35
<b>10 Troubleshooting</b> .....	36

2002, Quatech, Inc.

### NOTICE

The information contained in this document cannot be reproduced in any form without the written consent of Quatech, Inc. Likewise, any software programs that might accompany this document can be used only in accordance with any license agreement(s) between the purchaser and Quatech, Inc. Quatech, Inc. reserves the right to change this documentation or the product to which it refers at any time and without notice.

The authors have taken due care in the preparation of this document and every attempt has been made to ensure its accuracy and completeness. In no event will Quatech, Inc. be liable for damages of any kind, incidental or consequential, in regard to or arising out of the performance or form of the materials presented in this document or any software programs that might accompany this document.

Quatech, Inc. encourages feedback about this document. Please send any written comments to the Technical Support department at the address listed on the cover page of this document.

DOS, Windows 95, Windows NT are trademarks or registered trademarks of Microsoft Corporation. OS/2 is a registered trademark of IBM Corporation. All other trademarks or registered trademarks are property of their respective owners.

# 1 General Information

---

The Quatech, Inc. QSCP-200/300 provides four RS-422 or RS-485 asynchronous serial communication interfaces for IBM-compatible personal computer systems using the COMPACT PCI expansion bus. The QSCP-200/300 uses Quatech's new Enhanced Serial Adapter design. Legacy serial port data rates are limited to a maximum of 115,200 bits per second. Quatech Enhanced Serial Adapters can achieve data rates as high as 921,600 bits per second.

As a COMPACT PCI device, the QSCP-200/300 requires no hardware configuration. The card is automatically configured by the computer's BIOS or operating system. The four serial ports share a single interrupt line and are addressed in a contiguous block of 32 bytes. A special interrupt status register is provided to help software to manage the shared interrupt.

The QSCP-200/300's serial ports are implemented using 16750 Universal Asynchronous Receiver/Transmitters (UARTs). These UARTs contain hardware buffers (FIFOs) which reduce processing overhead and allow higher data rates to be achieved. The 16750 contains a 64-byte FIFO and can transmit and receive data at a rate of up to 921,600 bits per second. The 16750 is recommended for heavy multitasking environments and for applications involving high data rates.

The QSCP-200/300 is supported under several popular operating systems and environments. Contact the sales department for details on current software offerings. Most device drivers are available for download from the Quatech world wide web site at <http://www.quatech.com>.

## **Optional Features**

The standard QSCP-200/300 implements each of its communication channels with a 16750 UART and uses standard line driver and receiver components. For improved performance and industrial-grade reliability, Quatech offers the following board upgrades:

### **"D" Option --- D-37 Connector**

The "D" option provides the user with an octopus cable attached to the D-37 and with 4 D-25 connectors.

### **"M" Option --- Modular Connector**

The "M" provides the user with four 10-pin shielded modular connectors.

Quatech serial device drivers for Windows 95, Windows NT, and OS/2 provide support for the UART's 16750 mode. Other applications and/or operating systems may not support a UART operating in 16750 mode, in which case the default operation will be 16550-compatible mode.

## 2 Hardware Configuration

---

The QSCP-200/300 is automatically configured at boot time by the computer's BIOS or operating system. There are no required switches or jumpers to set for installation.

This chapter lists a number of jumper settings that control various hardware features. Jumpers J18-J25, located in a column near the D-37 connector, control the RS-422 or RS-485 signal line termination. Jumpers J6-J17 located in a column toward the center of the board, control how signals are routed from the UARTs to the connector, as well as full- or half- duplex operation. Jumpers J2-J5, grouped together at the end of the board opposite the D-37 connector, control special options.

Any changes from the factory default should be made before installing the QSCP-200/300 in the computer.

### RS-422 or RS-485 Signal Line Termination

Jumpers J18-J25 allow the selection of 100-ohm RS-422 termination, 120-ohm RS-485 termination, or no termination at all. The factory default, shown in Figure 1, is RS-422 termination. For full details, see page 0.

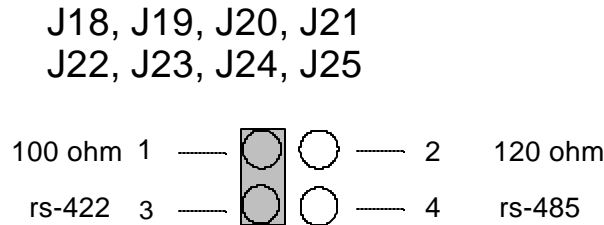

Figure 1 --- Factory default signal termination settings

## Signal Connections

The QSCP-200/300 provides each of four serial ports with four differential signal pairs: TxD, RxD, AUXOUT, and AUXIN. TxD and RxD are always present at the connector. The AUXOUT and AUXIN signals can be used to support RTS/CTS handshaking, external clocking, or external signal loopback. The factory default configuration, as shown in Figure 2, is a loopback of AUXOUT to AUXIN at the connector, with RTS and CTS looped back on the board. There is an extensive discussion of this topic starting on page 19.

### Full-duplex/Half-duplex Operation

The DTR or RTS modem control output of the UART can be used to enable and disable the transmit drivers. The inverse of these signals can also be used to enable and disable the receivers. These options are selectable per channel. The factory default, as shown in Figure 2, is for both the drivers and receivers of all channels to be continuously enabled. Two spare jumpers are installed in neutral positions. For details, refer to page 0.

The QSCP-200/300 is shipped from the factory with each channel configured as shown in Figure 2.

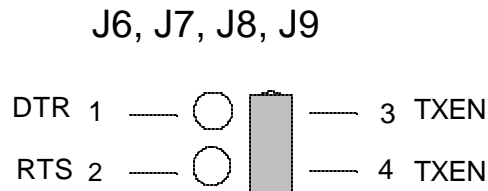
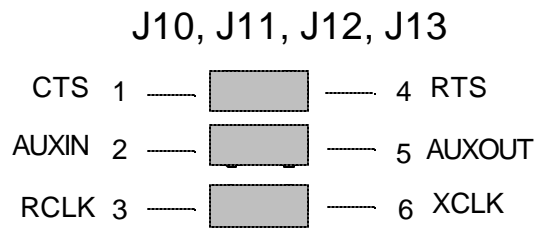

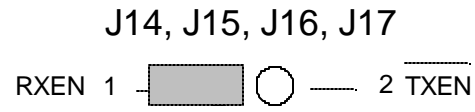

Spare jumpers hanging on one pin.

Figure 2 --- Factory default signal interface settings

## Clock Rate and Optional Registers

Figure 3 shows the jumper configuration as shipped from the factory, with two spare jumpers applied in neutral positions. Remove one or both and apply as shown in following subsections to set optional features.

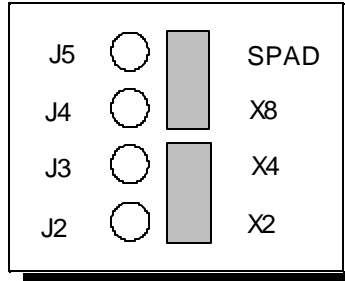

Figure 3 --- Factory default clock rate and options settings

### Enable Scratchpad Register (SPAD, J5)

In the default configuration, an Interrupt Status Register and an Options Register (see page 10) replace the scratchpad (base address + 7) of each UART. If the SPAD jumper is applied as in Figure 4, the UART scratchpad registers are enabled, and the Interrupt Status Register and the Options Register are not available.

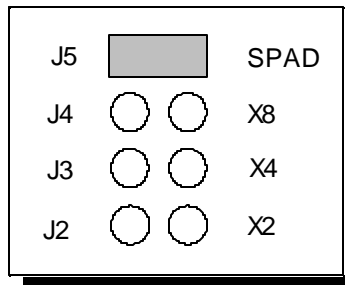

Figure 4 --- Enable scratchpad registers

## Force High-Speed UART Clock (X2, X4, or X8, J3-J5)

These jumpers force an increase of the UART input clock frequency by a factor of two, four, or eight. This feature can allow legacy software to use baud rates above 115,200 bits per second. It is also useful if the serial port device driver does not directly support setting the higher baud rates through the Options Register (see page 10).

If one of these jumpers is applied, it overrides any value written to the Options Register to set the clock multiplier by software. The effective baud rate will be either two, four, or eight times the value for which the UART itself is programmed.

The factory default is none of these jumpers applied, which allows for software control of the clock multiplier via the Options Register. The Options Register powerup default is for a standard times-1 clock of 1.8432 MHz for compatibility with standard serial ports.

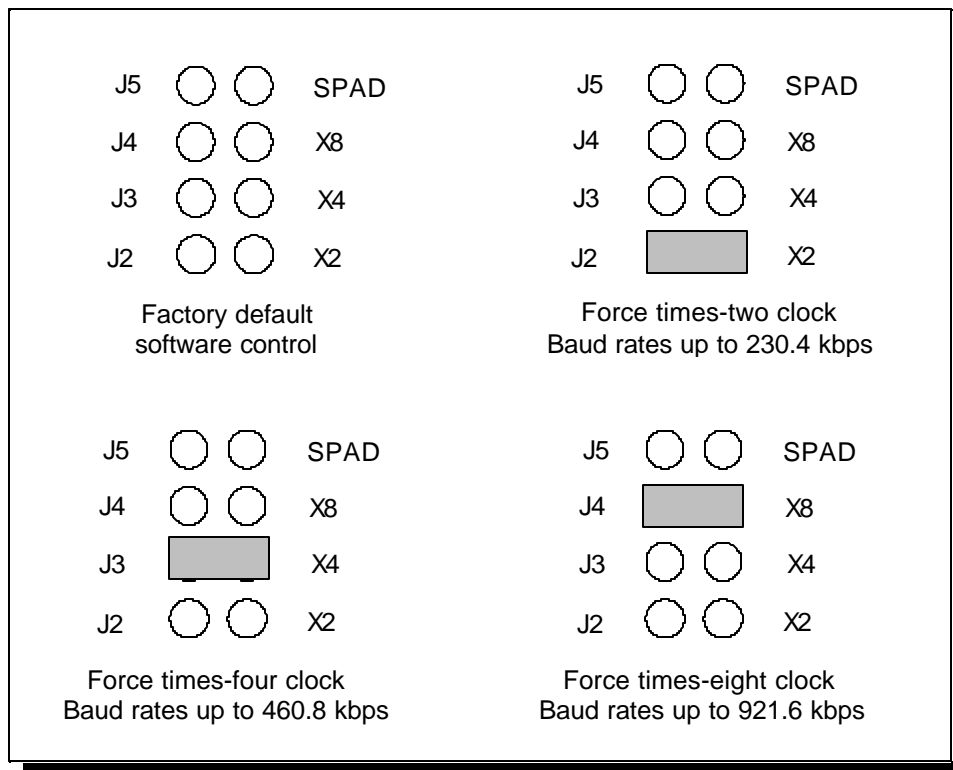

Figure 5 --- Clock multiplier jumper options

### 3 Hardware Installation

1. Turn off the power of the computer system in which the QSCP-200/300 is to be installed.
2. Remove the system cover according to the instructions provided by the computer manufacturer.
3. Make any desired optional jumper setting changes.
4. Install the QSCP-200/300 in any empty COMPACT PCI expansion slot. The board should be secured by installing the Option Retaining Bracket (ORB) screw.
5. Replace the system cover according to the instructions provided by the computer manufacturer.
6. Attach and secure the cable connectors to the desired equipment.
7. Turn on the power of the computer system.

The output of the QSCP-200/300 is a 37-pin D-connector. A cable is provided to convert the D-37 into four standard male D-25 connector.

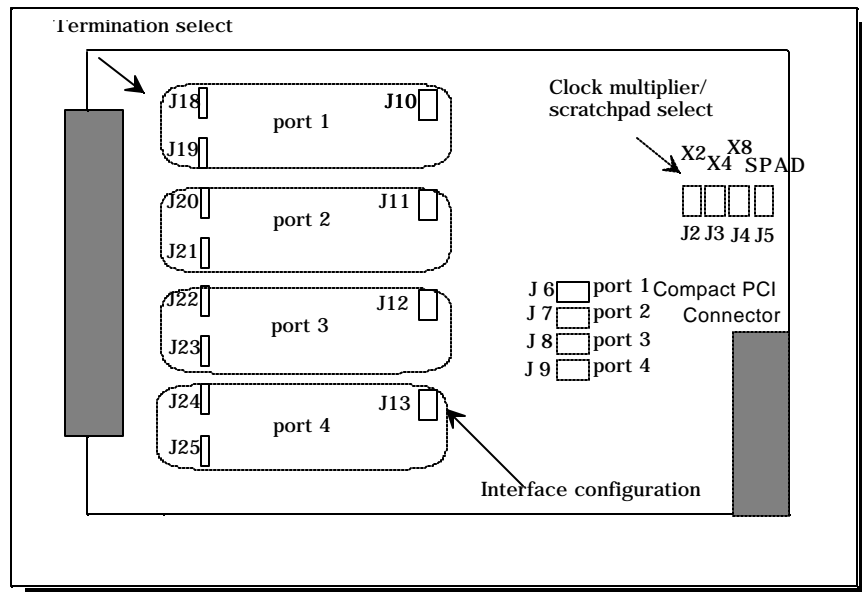

Figure 6 --- Jumper/connector locations

## 4 Address Map and Special Registers

---

This chapter explains how the four UARTs and special registers are addressed, as well as the layout of those registers. This material will be of interest to programmers writing driver software for the QSCP-200/300.

### Base Address and Interrupt Level (IRQ)

The base address and IRQ used by the QSCP-200/300 are determined by the BIOS or operating system. Each serial port uses 8 consecutive I/O locations. The four ports reside in a single block of I/O space in eight byte increments, for a total of 32 contiguous bytes, as shown in Figure 7.

Channel	I/O Address Range
Port 1	Base Address + 0 to Base Address + 7
Port 2	Base Address + 8 to Base Address + 15
Port 3	Base Address + 16 to Base Address + 23
Port 4	Base Address + 24 to Base Address + 31

Figure 7 --- Port Address Map

All four serial ports share the same IRQ. The QSCP-200/300 signals a hardware interrupt when any port requires service. The interrupt signal is maintained until no port requires service. Interrupts are level-sensitive on the COMPACT PCI bus.

The base address and IRQ are automatically detected by the device drivers Quatech supplies for various operating systems. For cases where no device driver is available, such as for operation under DOS, Quatech supplies the "QTPCI" DOS software utility for manually determining the resources used. See page 17 for details.

## Enabling the Special Registers

The QSCP-200/300 contains two unique registers, an Interrupt Status Register and an Options Register. These registers are enabled when the SPAD jumper (J5) is removed (factory default). They replace the UART Scratchpad Register on accesses to register address 7.

The Interrupt Status Register and Options Register are accessed through the scratchpad location of any UART. The DLAB bit of the UART (Line Control Register, bit 7) is used to select between the two registers. The most recent write of a DLAB bit in any UART selects between the two registers as shown in Figure 8.

<b>DLAB Bit</b>	<b>SPAD Jumper</b>	<b>Register selected for address 7 accesses</b>
0	removed	Interrupt Status Register
1	removed	Options Register
X	applied	Scratchpad Registers

Figure 8 --- DLAB bit selects between special registers

### Interrupt Status Register

The read-only Interrupt Status Register can be used to quickly identify which serial ports require servicing after an interrupt. Reading the Interrupt Status Register will return the interrupt status of the entire QSCP-200/300, as shown in Figure 9. The individual bits are cleared as the interrupting ports are serviced. The interrupt service routine should ensure that the interrupt status register reads zero before exiting.

<b>Bit</b>	<b>Description</b>
7 (MSB)	0 (not used)
6	0 (not used)
5	0 (not used)
4	0 (not used)
3	Port 4 --- 1 if interrupt pending
2	Port 3 --- 1 if interrupt pending
1	Port 2 --- 1 if interrupt pending
0	Port 1 --- 1 if interrupt pending

Figure 9 --- Interrupt Status Register

## Options Register

The Options Register allows software to identify the QSCP-200/300 as a Quatech Enhanced Serial Adapter. It also allows software to set the UART clock rate multiplier. Figure 10 shows the structure of the Options Register.

The powerup default of the Options Register is all bits zero.

Bit	Name	Description
7 (MSB)	ID1	ID bit 1
6	ID0	ID bit 0
5	-	(reserved, 0)
4	-	(reserved, 0)
3	-	(reserved, 0)
2	-	(reserved, 0)
1	RR1	Clock rate multiplier bit 1
0	RR0	Clock rate multiplier bit 0

Figure 10--- Options Register bit definitions

### Enhanced Serial Adapter Identification

The ID bits are used to identify the QSCP-200/300 as a Quatech Enhanced Serial Adapter. Logic operations are performed such that the values read back from these bits will not necessarily be the values that were written to them. Bit ID1 will return the logical-AND of the values written to ID[1:0], while bit ID0 will return their exclusive-OR.

Software can thus identify a Quatech Enhanced Serial Adapter by writing the ID bits with the patterns shown in the "write" column of Figure 11, then reading the bits and comparing the result with the patterns in the "read" column. Matching read patterns verify the presence of the Options Register.

Write		Read	
ID1	ID0	ID1	ID0
0	0	0	0
0	1	0	1
1	0	0	1
1	1	1	0

Figure 11 --- ID bit write/read table

### Clock Rate Multiplier

A standard serial port operates at a clock speed of 1.8432 MHz. In order to achieve higher data rates, Quatech Enhanced Serial Adapters can operate at two times, four times or even eight times this standard clock speed. This is controlled by the clock rate multiplier bits in the Options Register.

Software can determine the UART clock frequency by reading the clock rate multiplier bits RR1 and RR0 in the Options Register as shown in Figure 12. RR1 and RR0 can be set by writing to the Options Register if the X2, X4, and X8 jumpers (J2-J4) are all removed. If one of these jumpers is applied, the RR1 and RR0 bits are forced to the appropriate value. Reading the Options Register will always return the clock rate multiplier at which the board is operating.

<b>RR1</b>	<b>RR0</b>	<b>Clock Rate Multiplier</b>	<b>UART Clock Frequency</b>	<b>Maximum Data Rate</b>
0	0	X1 (default)	1.8432 MHz	115.2 kbaud
0	1	X2	3.6864 MHz	230.4 kbaud
1	0	X4	7.3728 MHz	460.8 kbaud
1	1	X8	14.7456 MHz	921.6 kbaud

Figure 12 --- Rate Register bit definition

At powerup and reset, the Options Register is initialized to 0. The QSCP-200/300 will thus powerup in the x1 mode with software control of the clock rate multiplier enabled as long as the X2, X4, and X8 jumpers are not installed.

Software can control high baud rates through a combination of changing the clock rate multiplier and the UART baud rate divisor. For example, a baud rate of 230.4 kbps could be achieved by setting the clock rate multiplier to X2 mode (or by applying the X2 jumper) and setting a software application for 115.2 kbps.

## 5 Windows Configurations

---

### Windows Millennium

1. After inserting the QSCP- 200/300 for the first time the "Add New Hardware Wizard" will begin. Select "Search for the best driver for your device.". Check the "Removable media" and "Specify location" box. Click the "Next" button.



3. Window will locate the proper INF file and copy the file from the CD. Click the "Next" button.
4. The final dialog screen will verify the file copy from the CD. Click the "Finish" button.

## Windows 2000

1. After inserting a QSCP-200/300/300 for the first time, the "Add New Hardware Wizard will appear at start up. Click the "OK" button.

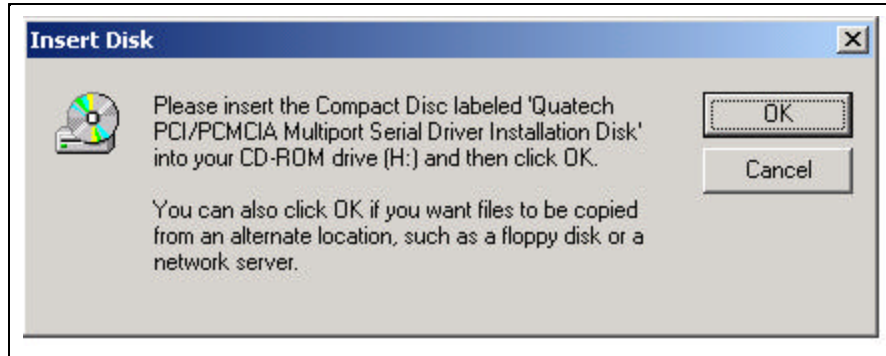

2. The following dialog box insert the Quatech COM CD (shipped with the device). Click the "OK" button.

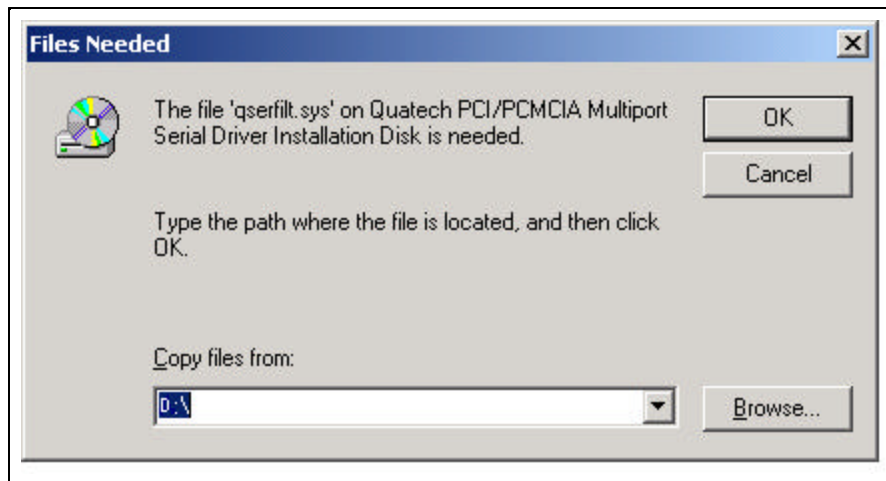

4. The following dialog box will display the appropriate INF file on the CD in drive. Click the "OK" button.
5. Window will copy the INF file from the CD and display a final dialog indication that the process is complete. Click the "Finish" button.

## Windows 98

1. After inserting a QSCP-200/300/300 for the first time, the "Add New Hardware Wizard will appear at start up. Click the "Next" button.
2. Select "Search for the best driver for you device". Click the "Next" button.



3. On the next dialog, select the "CD-ROM DRIVE" check box. Insert the Quatech COM CD (shipped with the device) into the CD-ROM drive. Click the "Next" button.



4. The following dialog box will display the appropriate INF file on the diskette in drive. Click the "Next" button.
5. Window will copy the INF file from the diskette and display a final dialog indication that the process is complete. Click the "Finish" button.

Windows 95 maintains a registry of all known hardware installed in your computer. Inside this hardware registry Windows 95 keeps track of all of your system resources, such as I/O locations, IRQ levels, and DMA channels. The "Add New Hardware Wizard" utility in Windows 95 was designed to add new hardware and update this registry.

An "INF" configuration file is included with the QSCP-200/300/300 to allow easy configuration in the Windows 95 environment. Also a custom Windows 95 serial device driver is included with the QSCP-200/300/300 to support the use of the 16750 UART's 64 byte fifo.

## **Windows 95**

### **Using the "New Hardware Found" Wizard**

The following instructions provide step-by-step instructions on installing the QSCP-200/300/300 in Windows 95 using the "New Hardware Found" wizard.

1. After booting the computer with a newly-installed QSCP-200/300/300, the "New Hardware Found" dialog box will appear. If you have never installed a Quatech PCI communications adapter before, the dialog box may simply indicate that it has found a "PCI Card."
2. Select the radio button for "Driver from disk provided by hardware manufacturer." Click the "OK" button to continue.
3. An "Install From Disk" dialog box should pop up. Insert the diskette with the Quatech INF files on it, select the correct drive letter, and click the "OK" button. Windows 95 automatically browses the root directory for an INF file that defines configurations for Multi-function Adapters. If no INF files are found, click the "Browse" button and search the Win95 sub directory on the installation diskette. You are not required to select the file name. After finding the directory containing the INF files, Windows 95 will choose the correct file.
4. The "New Hardware Found" dialog box will appear again, this time for an "Unknown Device."
5. Again select the radio button for "Driver from disk provided by hardware manufacturer." Click the "OK" button to continue.
6. Another "Install From Disk" dialog box will pop up. The path should already be pointing to the Quatech diskette. Click the "OK" button to continue.
7. You should now see the "Copying Files" dialog box as Windows 95 copies the driver files from the diskette.
8. The installation utility will ask for your Windows 95 installation disks. Serial communication ports require two drivers supplied by Microsoft to function: SERIAL.VXD and SERIALUI.DLL. Insert the disk or CD and click "OK".

**NOTE:**

You may be able to skip this step if you are certain that your system has the latest version of these files installed. If you do not have your Windows 95 install disks immediately available, click "OK" anyway. A dialog box appears with an option to Skip the files. Click the Skip button and the files will not be installed. This is all right if the latest version of these drivers are currently in the \WINDOWS\SYSTEM directory.

9. The "New Hardware Found" dialog will repeat for each of the serial ports on the QSCP-200/300/300 as each port is registered with Windows 95.
10. Installation is complete.

### **Viewing Resources with Device Manager**

The following instructions provide step-by-step instructions on viewing resources used by the QSCP-200/300/300 in Windows 95 using the "Device Manager" utility. Select Start | Help from within Windows 95 for additional information on this utility.

1. Double click the "System" icon inside the Control Panel folder. This opens up the System Properties box.
2. Click the "Device Manager" tab located along the top of the System Properties box. This lists all hardware devices registered inside the Windows 95 registry. Additional information is available on any of these devices by click on the device name and then selecting the "Properties" button.
3. Double click the device group "Multi-function Adapters". The QSCP-200/300/300 model name should appear in the list of Multi-function adapters.
4. Double click the QSCP-200/300/300 model name and a properties box should open for the hardware adapter.
5. Click the "Resources" tab located along the top of the properties box to view the resources Windows 95 has allocated for the QSCP-200/300/300 match the hardware configuration. **Because PCI is a true plug-and-play bus, do not attempt to modify the configuration values listed.** Click "Cancel" to exit without making changes.

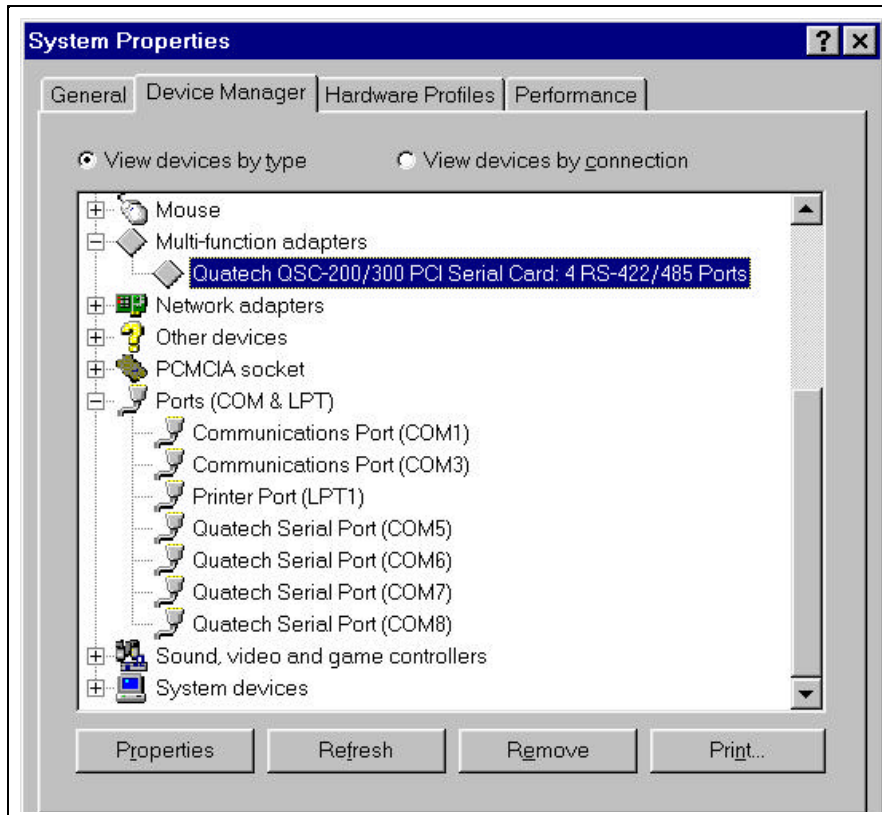

Figure 13--- Windows 95 Device Manager

6. The QSCP-200/300/300 serial ports are also listed under the group Ports (COM and LPT). Windows 95 does not assign COM1-COM4 to ports addressed at nonstandard locations. The QSCP-200/300/300 ports will be enumerated starting with COM5 (or higher) even if lower logical numbers are available.
7. Select any of the Quatech Serial Ports listed under the group Port (COM and LPT) and click the "Properties" button. This action opens a properties dialog for the specific COM port on the QSCP-200/300/300.
8. Click the "Port Settings" tab and then click the "Advanced" button. The QSCP-200/300/300 driver will display a custom Advanced Port Settings control, which allows the ports UART compatibility mode and FIFO threshold levels to be configured. The threshold values of full-scale for the transmit buffer and 3/4-scale for the receive buffer shown below are optimal for most applications. Note that the FIFO option for each of the QSCP-200/300/300's two ports is configured independently.

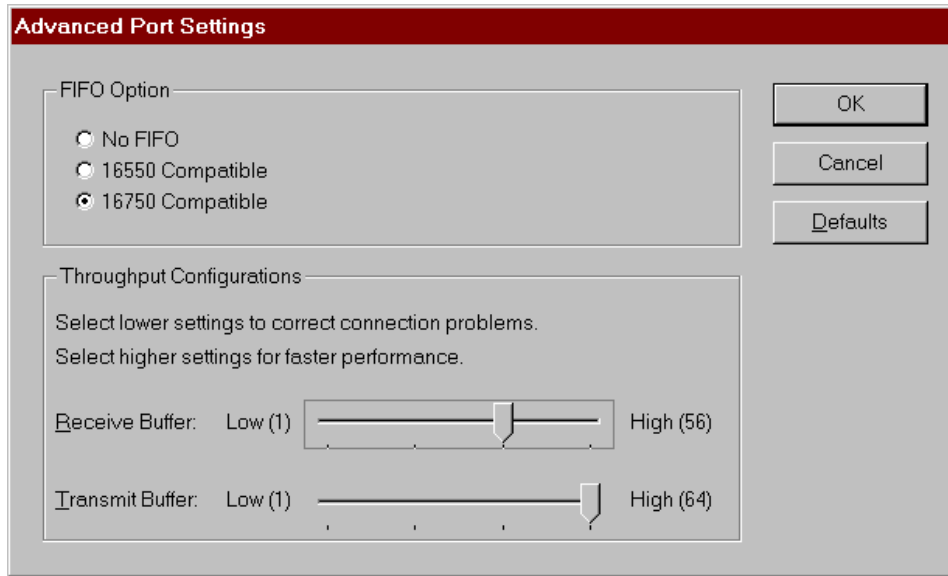

Figure 14 --- Windows 95 Device Manager

9. Use the Logical COM Port names to access the serial ports on your QSCP-200/300/300 through your software applications. Note: The Logical COM Port name is assigned to your ports by Windows 95. This name is required by a Windows 95 application when accessing a particular port.

## 6 Other Operating Systems

---

Device drivers for Windows NT and OS/2 are also available for the QSCP-200/300. The board can be used under DOS and other operating systems as well in many circumstances. The software described below can be obtained from the Quatech web site if it did not come with the board.

### **Windows NT**

The Windows NT device driver is installed by running the SETUP program. Up to 256 serial ports are supported. There is a command line-based configuration utility which is used for adding PCI bus and ISA bus serial ports. Please refer to the documentation included with the device driver for full installation and configuration details.

### **OS/2**

The OS/2 device driver supports up to 32 serial ports in a system. Installation is a manual, but simple, process. Please refer to the documentation included with the device driver for full installation and configuration details.

### **DOS and other operating systems**

The QSCP-200/300 is not a direct drop-in replacement for a legacy serial port because its base address and IRQ cannot be fixed at values such as 3F8 hex, IRQ 4 (COM1) or 2F8 hex, IRQ 3 (COM2), etc. Rather, the system BIOS assigns the address and the IRQ in a plug-and-play fashion at boot time. Software which is to use the QSCP-200/300 must be able to accommodate any valid assignments of these resources.

For Windows 95, Windows NT and OS/2, the Quatech device drivers determine what the resource assignments are and proceed accordingly. In other cases, however, the user must intervene. The discussion below will center on DOS, but the concepts can be applied to other operating systems as well.

Many DOS applications support user configuration of the base address and IRQ of a serial port. Such applications can generally make use of the QSCP-200/300. Older applications, as well as some custom software, may use hard-coded standard legacy serial port addresses. These applications will require modifications to support PCI devices.

Custom applications for which the customer has source code can be modified to make just a few PCI BIOS function calls to obtain all the necessary configuration information. The PCI BIOS specification can be obtained from the PCI Special Interest Group. Contact Quatech technical support for more information.

### **QTPCI.EXE**

Quatech's "QTPCI" utility supplies the information required when modifying the serial port settings of the application. This program should be run from real DOS, not in a Windows DOS box.

Figure 15 shows the Basic Mode display for the QSCP-200/300 after the "Q" key has been pressed. In this example, the QSCP-200/300 uses I/O base address FF80 hex and IRQ 3. The hardware revision of the QSCP-200/300 is also displayed. Pressing the "N" key will show similar information for all non-Quatech PCI devices in the system, including those devices integrated on the motherboard.

**The QTPCI program is capable only of displaying the PCI configuration. It cannot be used to make changes.**

```

Quatech PCI Configuration Information Display Software
Version 1.00

INSTRUCTIONS:
-----
Press keys listed in the menu at the bottom of the screen.
This program only displays information. It cannot make changes.
Numbers preceded by "0x" are hexadecimal.

PCI BIOS detected, version 2.10

Quatech PCI adapters detected
-----
QSC-200/300 Four-port RS-422/485 adapter          (Hardware Revision A1)
Uses IRQ 3
Base addr 1 = 0xff80      I/O

Q - Quatech PCI adapters          M - Change to Expert Mode
N - Other PCI devices
X - EXIT

```

Figure 15 --- QTPCI.EXE Basic Mode display

Figure 16 shows the Expert Mode display for the QSCP-200/300 after the "Q" key has been pressed. The information from the Basic Mode display is presented along with more details such as the Vendor and Device IDs, PCI Class Code, size of memory and I/O regions, etc. Pressing the "N" key will show similar information for all

non-Quatech PCI devices in the system, including those devices integrated on the motherboard. In this example, the "Base addr 0" resource is reserved.

For users interested in even more details, PCI BIOS information can be displayed by pressing the "B" key. Pressing the "I" key displays the PCI interrupt routing table.

```
Quatech PCI Configuration Information Display Software
Version 1.00

Quatech PCI adapters detected
-----
QSC-200/300 Four-port RS-422/485 adapter
Vendor ID 0x135c, Device ID 0x0040 found in slot 0x04 on bus 0x00
Device/Function code = 0x98, Revision ID = 0x01 (Hardware Revision A1)
PCI Class Code = 0x070200 Communications controller, multiport serial
Subsystem Vendor ID 0x135c, Subsystem ID 0x0040
INTA# mapped to IRQ 3 (route 0x61)
Base addr 0 = 0xfc80    I/O    0x80 bytes allocated
Base addr 1 = 0xff80    I/O    0x20 bytes allocated

Q - Quatech PCI adapters          M - Change to Basic Mode
N - Other PCI devices             B - PCI BIOS details
X - EXIT                          I - Interrupt routing details
```

Figure 16 --- QTPCI.EXE Expert Mode display

## 7 External Connections

The QSCP-200/300 provides four differential communication signals per channel. The two output signals are Transmit Data (TxD) and Auxiliary Output (AUXOUT). The two input signals are Receive Data (RxD) and Auxiliary Input (AUXIN). A ground signal is also provided.

The available input signals for AUXIN are Clear To Send (CTS) and the Receive Clock (RCLK). The available output signals for AUXOUT are Request To Send (RTS), the Transmit Clock (XCLK), and the AUXIN signal (for loopback). Either half-duplex or full-duplex operation can be selected for each communications channel. If half-duplex operation is selected, one of the UART's signals (either DTR or RTS) is used to enable the transmitter drivers. The inverse of the transmitter enable can be used to enable the receiver drivers.

Factory-installed resistors allow for signal line termination in compliance with the RS-422 and RS-485 standards. The desired termination can be selected or removed per port by applying a jumper.

Configuration is done using jumpers J18 through J25 for termination selection, and jumpers J6 through J17 for interface signal routing. Each jumper block provides the same functions for its particular channel.

Channel	Termination	Signal routing
Port 1	J18, J19	J6, J10, J15
Port 2	J20, J21	J7, J11, J14
Port 3	J22, J23	J8, J12, J16
Port 4	J24, J25	J9, J13, J17

Figure 17 --- Jumper/Channel correspondence

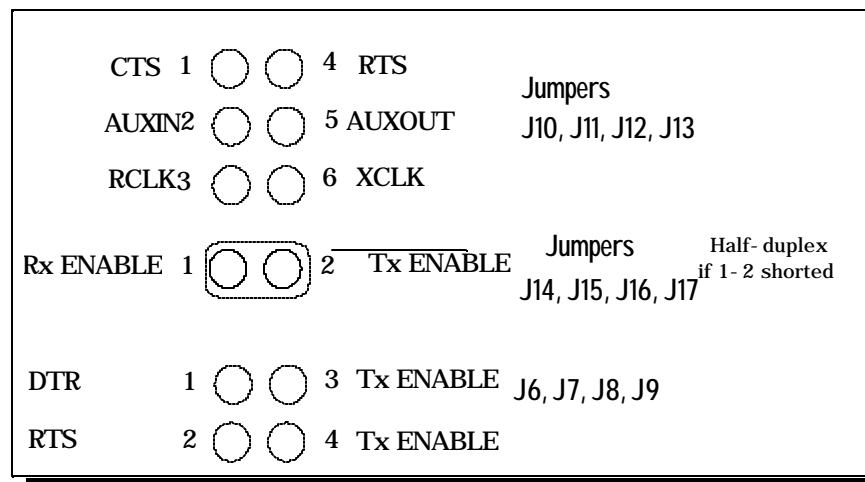

Figure 18 --- Pinout of jumpers J9-J16

## RTS/CTS Handshake

Transmission of RTS, combined with reception of CTS, allows for hardware handshaking (data flow control) between the UART and the external device. RTS is transmitted on AUXOUT by connecting pins 4 and 5 of the jumper block. CTS is received on AUXIN by connecting pins 1 and 2 of the jumper block. If RTS/CTS handshaking is not desired, the RTS output can be looped back to the CTS input by connecting pins 1 and 4 of the jumper block. Figure 19 shows how to select the RTS/CTS mode.

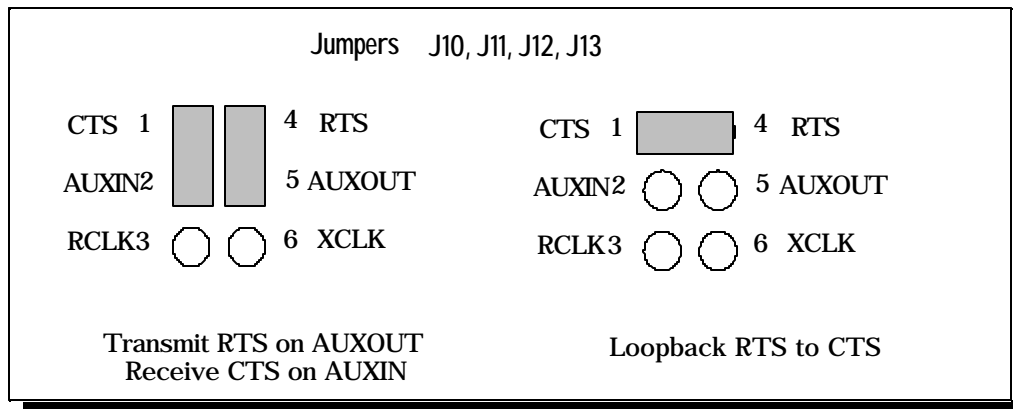

Figure 19 --- RTS/CTS selection

## RCLK

This is the clock signal used by the receiver portion of the UART. It is generally provided by connecting it to the UART's own transmit clock output (XCLK). This is done by connecting pins 3 and 6 of the jumper block. If desired, RCLK can be received from an external source over the AUXIN line by connecting pins 2 and 3 of the jumper block. Figure 20 shows how to select the RCLK mode.

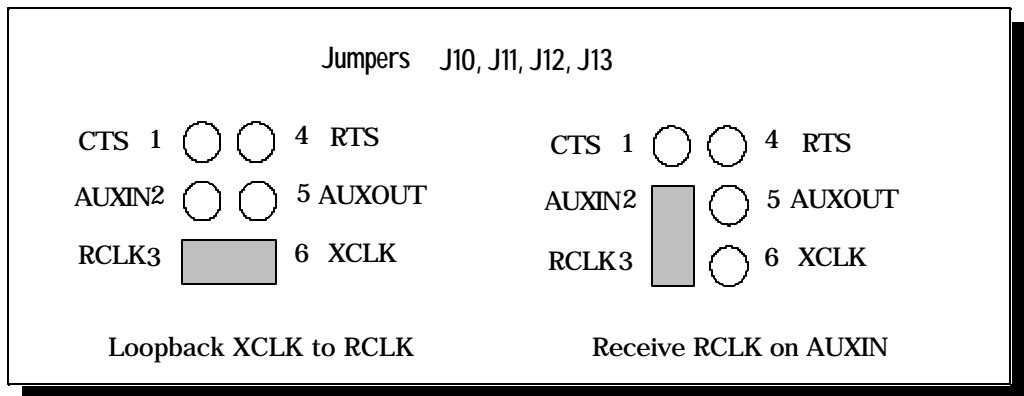

Figure 20 --- RCLK selection

## XCLK

This is the output clock signal used by the transmitter portion of the UART. It is generally connected to the UART's own receive clock input (RCLK). This is done by connecting pins 3 and 6 of the jumper block. If desired, XCLK can be transmitted to an external source over the AUXOUT line by connecting pins 5 and 6 of the jumper block. Figure 21 shows how to select the XCLK mode.

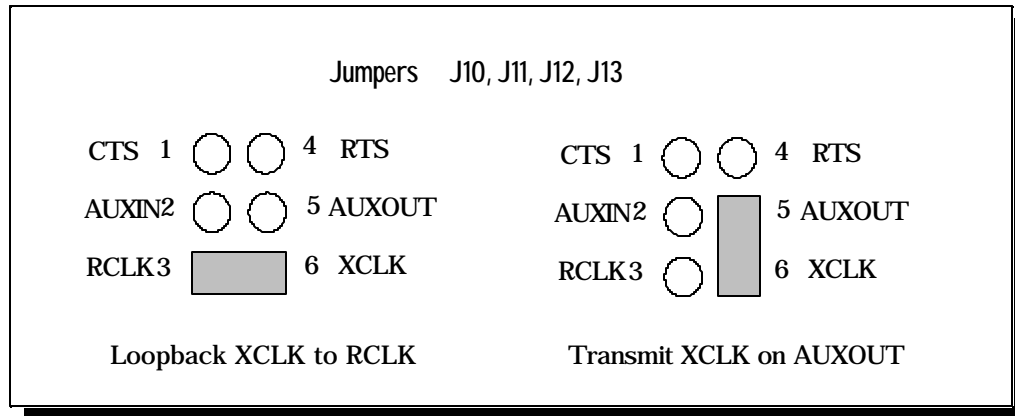

Figure 21 --- XCLK selection

## AUXIN/AUXOUT Loopback

The AUXIN signal is an input from the external device, and connecting it to the AUXOUT signal provides for a loopback mode of operation. In other words, whatever signal is transmitted by the external device over the AUXIN line will be fed back to the external device over the AUXOUT line. This mode is accomplished by connecting pins 2 and 5 of the jumper block. Figure 22 shows how to select this loopback mode.

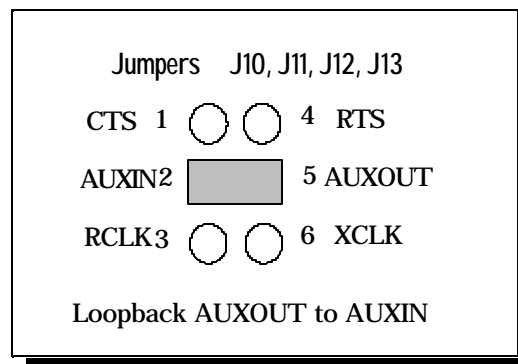

Figure 22 --- AUXIN/AUXOUT loopback

## Half-Duplex/Full-Duplex Selection

Using jumper blocks J6-17, the transmitters and receivers of each channel can be enabled and disabled by modem control signals. This allows operation in both half-duplex or full-duplex modes.

The transmit drivers can be controlled by either the Data Terminal Ready (DTR) or the Request to Send (RTS) output from the UART. If a jumper is applied between pins 1 and 4, the drivers are enabled for TxD and AUXOUT when the UART's DTR signal is asserted. If a jumper is applied between pins 2 and 5, the drivers are enabled for TxD and AUXOUT when the UART's RTS signal is asserted. If neither of these jumpers is applied, the drivers remain enabled at all times. When disabled, the transmit drivers enter a high-impedance state.

The receivers can be controlled by the inverse of the transmit enable. If a jumper is applied between pins 3 and 6, the receivers for RxD and AUXIN will be disabled when the transmit drivers are enabled and vice-versa (based on the DTR or RTS connections on pins 1-4 or 2-5).

To operate in half-duplex DTR mode, apply jumpers between pins 1 and 4 and pins 3 and 6. To operate in half-duplex RTS mode, apply jumpers between pins 2 and 5 and pins 3 and 6.

To operate in full-duplex mode, leave the jumpers in their factory default locations, installed in the spare locations of 4-5 and 6-only. The drivers and receivers are always enabled in full-duplex mode. Figure 23 shows how to select half- or full-duplex operation.

### **WARNING:**

When operating in half-duplex mode, the transmitter drivers must be disabled before receiving any data. Failure to do so may result in multiple active output drivers being connected together, which may cause damage to the board, the computer, and the external

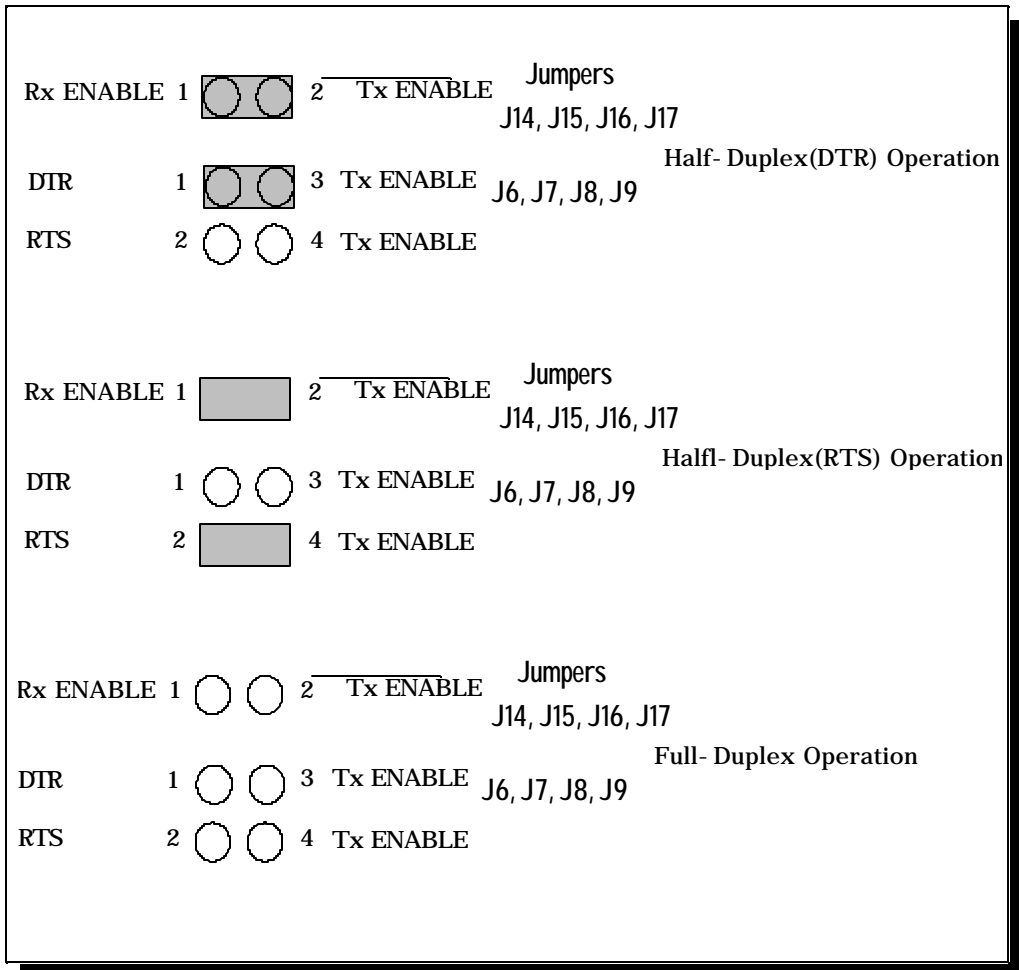

Figure 23 --- Half- or full-duplex selection

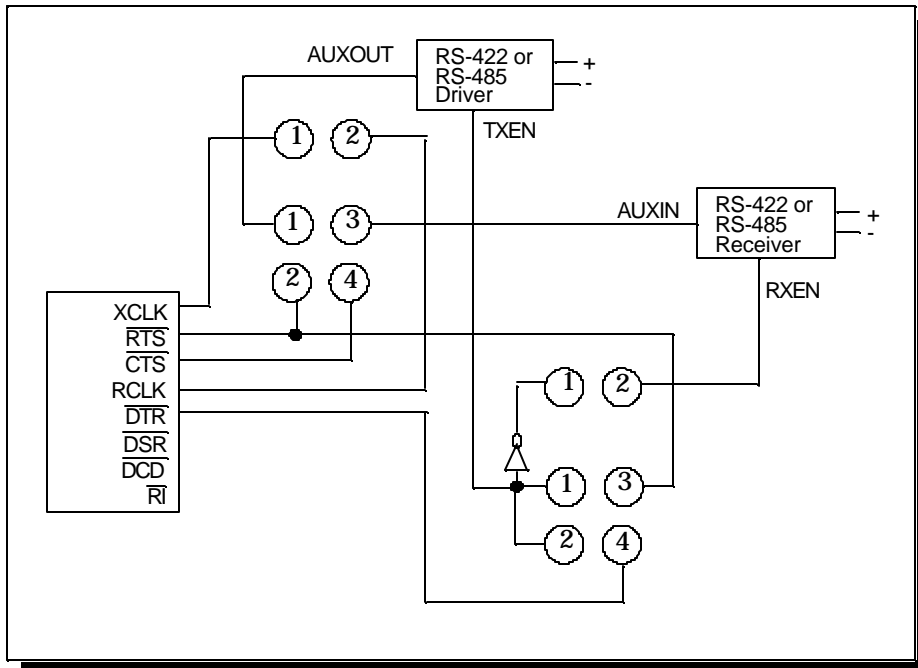

Figure 24 --- Output control block diagram

## Termination Resistors

Line termination resistors are provided for the input signals of each of the QSCP-200/300's RS-422/485 ports. Termination may be selected or removed for individual signal lines using jumper blocks J18-25.

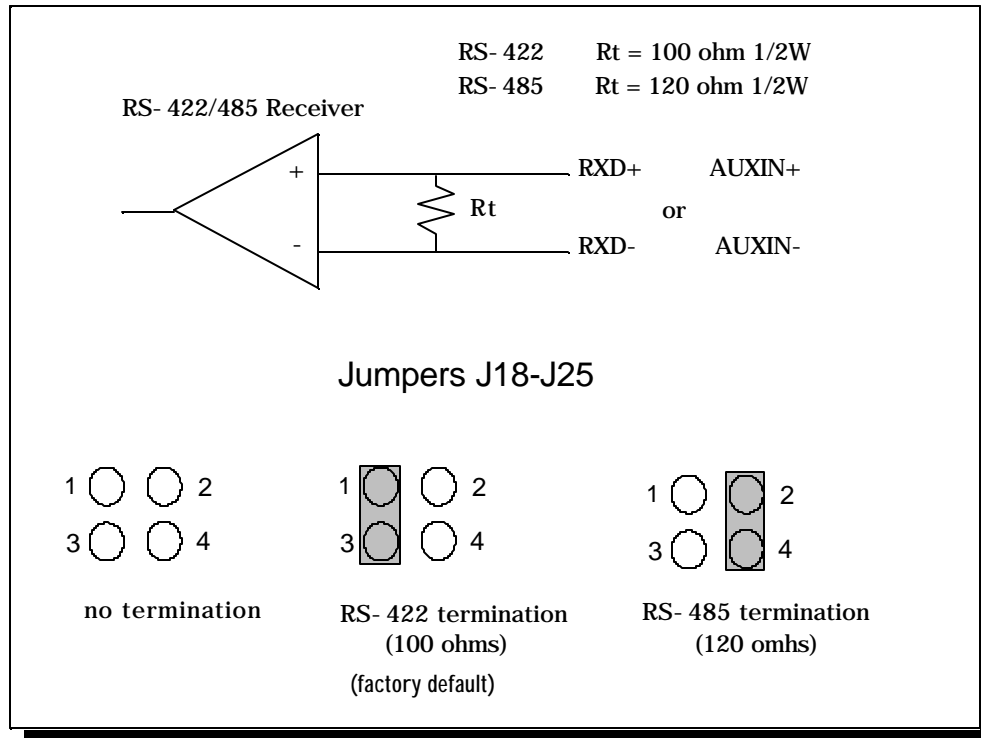

Figure 25 --- RS-422/485 Line termination resistance values

## RS-422/485 Peripheral Connection

The QSCP-200/300 connects to peripheral equipment through a female D-37 connector, or using the optional adapter cable, four male D-25 connectors. The serial port connector definitions are listed in Figure 26.

Signal Description	Port 1		Port 2		Port 3		Port 4	
	D-37	D-25	D-37	D-25	D-37	D-25	D-37	D-25
TxD+	24	2	10	2	33	2	19	2
TxD-	5	3	28	3	14	3	37	3
RxD+	23	4	9	4	32	4	18	4
RxD-	4	5	27	5	13	5	36	5
AUXOUT+	21	20	7	20	30	20	16	20
AUXOUT-	22	6	8	6	31	6	17	6
AUXIN+	20	22	6	22	29	22	15	22
AUXIN-	2	8	25	8	11	8	34	8
GND	3	7	26	7	12	7	35	7

Figure 26 --- QSCP-200/300 connector definitions

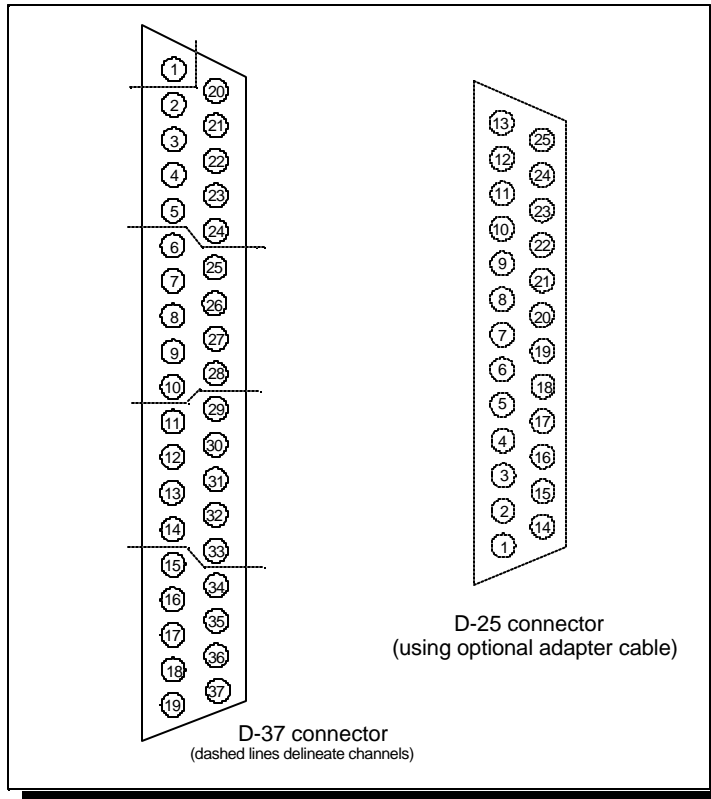

Figure 27 --- QSCP-200/300 output connectors

## 8 PCI Resource Map

---

Listed below are the PCI resources used by the QSCP-200/300. Such information may be of use to customers writing their own device drivers or other custom software. A detailed description of the QSCP-200/300's UARTs is available on the Quatech web site.

(all numbers in hex)

PCI Vendor ID:	0x135C	Quatech, Inc.
PCI Device ID:	0x0140	QSCP-200/300
PCI Class Code		
Base class:	0x07	Simple communications controller
Subclass:	0x02	Multiport serial controller
Interface:	0x00	
IRQ sourced by:	INTA#	
Base address 0:	0x80 bytes I/O	Reserved region
Base address 1:	0x20 bytes I/O	Serial ports
		Port 1 at offset 0x00
		Port 2 at offset 0x08
		Port 3 at offset 0x10
		Port 4 at offset 0x18

## 9 Specifications

---

Bus interface:	PCI, 32-bit bus, 5-volt only IBM-compatible computers
Dimensions:	approx. 5.5" x 3.5"
Serial ports	
Controller:	16550 with 16-byte FIFOs <b>(16750 with 64-byte FIFOs optional)</b>
Interface:	One female D-37 connector Four male D-25 connectors using adapter cable
Transceivers:	SP491 or compatible
Differential output:	2V min. with 50-ohm load (RS-422) 1.5V min. with 27-ohm load (RS-485)
Output rise/fall time:	3ns min., 40ns max., 15ns typ.
Differential input threshold:	-0.2V min., +0.2V max.
Input resistance:	12k ohm min., 15k ohm typ.
Input current:	+/- 1.0mA max.
Power requirements	
+5 volts:	approx. 320 mA
Temperature:	operating 0° to 70° storage -50° to 80°
Humidity:	10% to 90%

# 10 Troubleshooting

---

Listed here are some common problems and frequent causes of those problems. If the information here does not provide a solution, contact Quatech technical support.

Any unauthorized repairs or modifications will void the QSCP-200/300's warranty.

## **Computer will not boot up.**

1. Is the QSCP-200/300 properly inserted? Remove the card and try again. Perhaps try a different expansion slot.
2. Ensure that an ISA-bus card is not using the same IRQ that the PCI BIOS tries to assign to the QSCP-200/300. Most computers have BIOS setup options to reserve IRQs for either ISA or PCI use. Try reserving the IRQ for the ISA card. The BIOS will automatically choose a different IRQ for the QSCP-200/300. An address conflict is unlikely because most PCI-based computers will assign I/O addresses in such a way that they cannot conflict with ISA-bus devices.
3. The QSCP-200/300 may be defective. Contact technical support for instructions.

## **Cannot communicate with other equipment.**

1. Are the cable connections correct? Are the cables securely attached?
2. Is the software configured with the correct base address and IRQ information for the QSCP-200/300? (This is mainly a DOS issue.)
3. Is the device driver installed?
4. If you are trying to communicate with another DTE, a null-modem cable will be required.
5. If possible, use a loopback connector to test the port.

QSCP-200/300  
User's Manual  
Revision 1.03  
July 2002  
P/N: 940-0176-100